

# Development of Computerized Classroom Participatory Action Research (CCPAR) System

Panana Tangwannawid<sup>a</sup>, Monchai Taintong<sup>b</sup> and Sageemas Na Wichian<sup>c</sup>

Faculty of Information Technology,  
King Mongkut's University of Technology North Bangkok,  
Thailand

E-Mail: <sup>a</sup>panana.t@gmail.com, <sup>b</sup>monchai@kmitnb.ac.th, <sup>c</sup>sageemas@gmail.com

## Abstract

*The purposes of this research, development Computerized Classroom Participatory Action Research (CCPAR) system. The research processes we studied the related information, selected the application prototype based on studied criteria, and developed the system using PHP language and MySQL database, Then, Beta test was performed by 6 experts.*

*The results from analyzed data. Security Test were at very good level ( $\bar{x}=4.50$ , S.D. =0.55). Functional Requirement Test were at good ( $\bar{x}=4.3$ , S.D. =0.81). Usability Test were at good ( $\bar{x}=4.16$ , S.D. =0.98). Functional Test were at good ( $\bar{x}=4.00$ , S.D. =1.09), and Output Validation Test were at good ( $\bar{x}=4.30$ , S.D. =1.03).*

**Keywords:** Participatory Action Research, Classroom Action Research, Computerized Classroom Participatory Action Research System.

## 1. Introduction

Learning development with research will emphasize at Action Research that has important aim is taking research result to develop learning [1] that regard as research is study strategy that important to teaching and studying quality development. Action

research come from word "Action" and "Research" that is stressing meaning that will use research for develop as method in increase knowledge about teaching and learning that Action Research will help in provide Method Working that link between theory and action to become one from idea to practice. KEMMIS & MC TAGGART give Action Research meaning that is problem or question collection from reflection and practice of person who has participate in any society to want to develop principle, reason and practice method for receive form or method to use in practice quality development. Meanwhile, it has also been understand development about practice to be in line with existence society and situation that relate .

Action research is focused on problem solving through inquiry into human problems in areal context. It is fundamentally different from the research carried out in the laboratory where through the rigors of carefully defined variables and careful hypothesis testing researchers generate explanations and develop new theories.[2] The steps for carrying out action research differ from subject to subject, but the basic procedure is:

First step – researchers observe the situation carefully, working with those at the research location to define and describe the problem to be investigated, along with a description of the environment or context of the problem situation

Second step – participants (the researchers and the community) analyze and interpret the situation to deepen their understanding of the background and extent of the problem, and to identify as well other players who may be implicated. A general review of the literature may be carried out at this step

Third step – participants plan an action that will lead to resolving the problem, carry out the action, and evaluate the results to assess whether the action led to the resolution of the problem.[3][4]

Action research is used frequently in the field of education: three excellent examples are projects that focused on the role of schools in information literacy [5], on web-based distance education. [6]

The PDCA (or PDSA) Cycle was originally conceived by Walter Shewhart in 1930's, and later adopted by W. Edwards Deming. The model provides a framework for the improvement of a process or system. It can be used to guide the entire improvement project, or to develop specific projects once target improvement areas have been identified.

Plan – P is any work should have planning because occur confidents that will work to complete such as plan teaching, plan research.

Do – D is practice step according to plan that planning. Research in classroom according to research plan is collect data for answer research problem that determine in planning step.

Check – C is step of evaluating work that is according to plan that prepare. This check will receive the thing that want according to plan and the thing that is defect that must correct.

Action – A is step of taking defect to planning for correct.

It will see that Classroom Action Research or CAR is research that is principle to development, studying – teaching. The person who has important role is teacher who

perform duty as all teacher in classroom and researcher that Classroom Action Research has important aim is develop quality of studying – teaching to occur the best result. The teacher must emphasize solvability in situation or lesson of classroom regard to be process that help to solve or develop teaching – studying process as system.

The Frame Idea

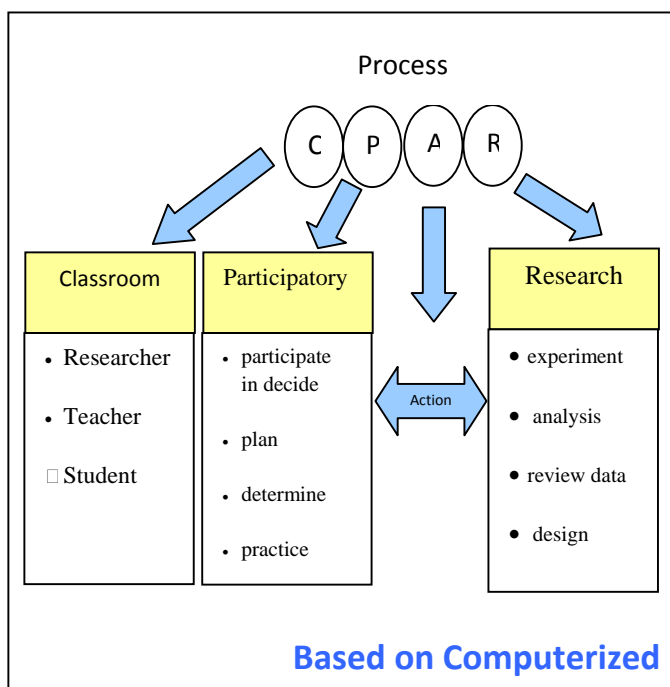

Figure 1: Frame idea of CCPAR [7]

From Figure 1, it shows working process of CCPAR model that use technology of computer to support studying – teaching. Instructor, students, and researcher have participate in teaching – studying. Classroom Participatory Action Research by use computer has meaning cover person who relate with teaching – studying of practice, research, experiment, analysis together by use data and information together for all person who relate help develop learning that suitability in Classroom. Every process is on base of using computer. It has 4 main parts such as:

**C: Classroom** is research by use data and information that is in classroom by include 3 groups is instructor, students , and researcher.

**P: Participatory** is participatory synthesizing of every side. 6 elements are participate in decide, plan, determine demand, practice, evaluate and accept result that receive.

**A: Action** is cover study practice, analysis, research with researcher, specialist, teacher and student is step that take activity of practice that participate in accept to determine as practice plan. In this is creating plan of information course teaching for life for be method in teaching by every groups has participate in creating teaching plan.

**R: Research** use process of research to study, experiment, analysis is determine problem, review data, design, keep data, analysis, summarize, suggest and report data result that receive from research of research method.

## 2. Objective

The objective of a development of Computerized Classroom Participatory Action Research [CCPAR] system.

## 3. Development of CCPAR system

System Development Life Cycle (SDLC) in reference to adaptive waterfall process as adopted and described by Dennis and Wixom. The major phase consists of Planning, Analysis, Design and Implementation.

### 3.1 Computerized Classroom Participatory Action Research (CCPAR) Model

CCPAR model that consists of 3 steps as follows : 1) Planning, 2) Acting, and 3) Evaluation. Planning step is the first step for instructor, students, and researcher to plan how to proceed the lesson using chat, web board, e-mail and other respectively. Acting step is the second step for instructor,

and students the lesson that consists of 1) introduction, 2) conducting, and 3) conclusion. The tools for the second step are chat, web board respectively. Evaluation step is the last step of CCPAR model for evaluate the lesson for instructor, students , and researcher using e-mail, web board and chat respectively. [8]

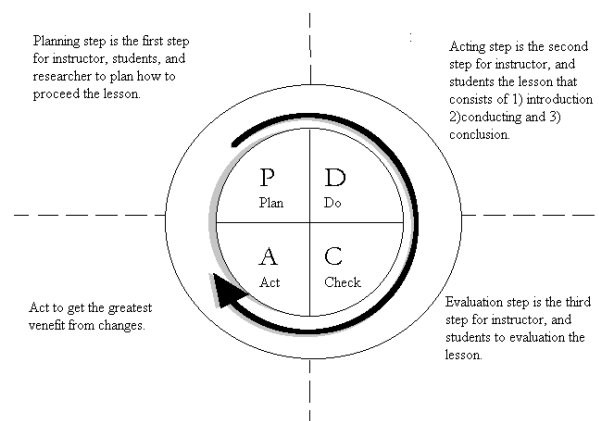

Figure 2: A Synthesis of CCPAR model

## 3.2 The System Architecture

Information and communications technology presents growing opportunities for learning and teaching. It has the potential to improve the effectiveness of student learning, It can also improve the efficiency of schools and education systems in delivering, managing and reporting on educational services. Importantly, applications software are required to provide manage access to digital resources and information. CCPAR system is applications software that provides the real functionality available through ICT.

The CCPAR is developed with Java and XML via HTTP. There are four part : 1) Database Management 2) CCPAR that consists of 2.1) Planning, 2.2) Acting, and 2.3) Evaluation 3) User Interface Management System and 4) Input and Output.

The architecture of CCPAR can be purposely created as shown in Figure 3.

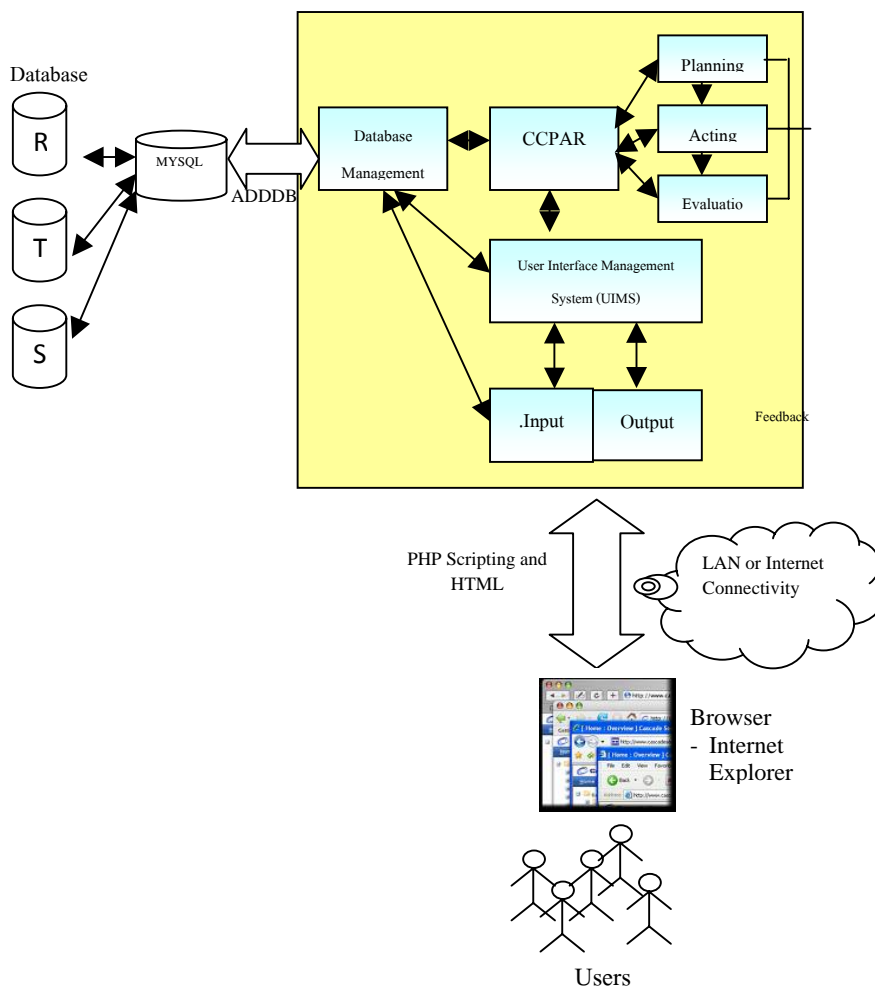

Figure 3: The Architecture of CCPAR system [9]

#### 4. Result

The results was a development CCPAR system that consists of 5 part as follows :

- 1) Functional Requirement Test
- 2) Functional Test
- 3) Output Validation Test
- 4) Usability Test and
- 5) Security Test

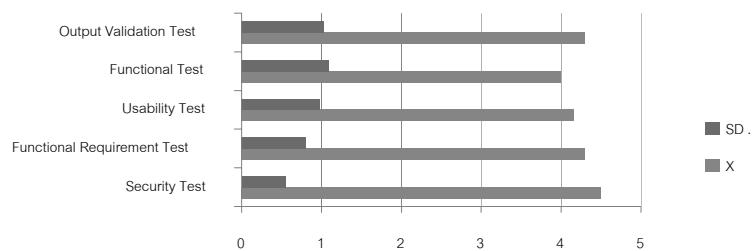

Figure 4: Show the graph presents result.

From Fig. 4 Show the graph presents 5 part. Security Test were at very good level ( $\bar{x}=4.50$ , S.D. =0.55). Functional Requirement Test were at good ( $\bar{x}=4.3$ , S.D. =0.81). Usability Test were at good ( $\bar{x}=4.16$ , S.D. =0.98). Functional Test were at good ( $\bar{x}=4.00$ , S.D. =1.09), and Output Validation Test were at good ( $\bar{x}=4.30$ , S.D. =1.03).

## 5. Discussion

This paper introduces research in the area of classroom action research and participatory action research for researcher, instructor, and students, which resulted in the development of the CCPAR system. This paper describes a architecture for supporting the 1) Planning module, 2) Acting module, and 3) Evaluation module. The paper concludes by outlining the initial CCPAR system evaluation results.

## 6. References

- [1]Panana Tangwannawit, Monchai Taintong. 2006. Computerized Classroom Participatory Action Research. The 6<sup>th</sup> National Symposium on Graduate Research 13-14 Oct 2006. Chulalongkorn University. Thailand.
- [2]Ann Curry. 2005. Action Research in Action: Involving Students and Professionals. World Library and Information Congress: 71th IFLA General
- [3]Robson, Colin. 2002. Real World Research.. 2<sup>nd</sup>
- [4] Stringer, Ernest. 1999. Action Research.. 2<sup>ed</sup>. London: Sage Publications.
- [5]Barrett. L., Danks, M. 2003. Information Literacy: A Crucial Role for Schools. Library +Information Update 2.
- [6]Knop, Nancy, and Lamaster, Kathryn. 2004. Improving Web-based Instruction: Using Action Research to Enhance Distance Learning Instruction. Educational Action Research.
- [7]Panana Tangwannawit, Monchai Taintong. 2007. A synthesis of Classroom Participatory Action Research The 3<sup>rd</sup> National Conference on Computing and Information Technology 25-26 May 2007, Thailand.
- [8]Panana Tangwannawit, and Monchai Taintong. "A Synthesis of Computerized Classroom Participatory Action Research (CCPAR) Model". The 2008 International Joint Conference on e-Commerce, e-Administration, e-Society, and e-Education (e-CASE 2008). 2008.
- [9]Panana Tangwannawit, Monchai Taintong. 2008. Design Computerized Classroom Participatory Action Research Model. The 4<sup>th</sup> National Conference on Computing and Information Technology Thailand.