

PI, Fuzzy Logic Controlled Shunt Active Power Filter for Three-phase Four-wire Systems with Balanced, Unbalanced and Variable Loads

B.Suresh Kumar

EEE Department, CBIT, Hyderabad.
Mail:bskbus@gmail.com

K.Ramesh Reddy

EEE Department, GNITS, Hyderabad.
Mail: kollirameshreddy@yahoo.co.in

V.Lalitha

EEE Department, CBIT, Hyderabad.
Mail:bskbus@gmail.com

Abstract- This paper presents a fuzzy logic, PI controlled shunt active power filter used to compensate for harmonic distortion in three-phase four-wire systems. The shunt active filter employs a simple method for the calculation of the reference compensation current based on Fast Fourier Transform. The presented Shunt Active Power filter is able to operate in balanced, unbalanced and Variable load conditions. Classic filters may not have satisfactory performance in fast varying conditions. But auto tuned active power filter gives better results for harmonic minimization, reactive power compensation and power factor improvement. The proposed auto tuned shunt active filter maintains the THD well within IEEE-519 standards. The proposed methodology is extensively tested for wide range of different Loads with Improved dynamic behavior of shunt active power filter using fuzzy logic, PI controllers. The results are found to be quite satisfactory to mitigate harmonic Distortions, reactive power compensation and power factor improvement.

Keywords— Active power filter, Fuzzy logic controller, PI controller, Power

factor correction, Power quality improvement

I. INTRODUCTION

In recent years, power quality distortion has become serious problem in electrical power systems due to the Increase of nonlinear loads drawing non-sinusoidal currents Active filters have been widely used for harmonic mitigations well as reactive power compensation, load balancing, voltage regulation, and voltage flicker compensation In three-phase four-wire systems with nonlinear loads a high level of harmonic currents in both the three line conductors and more significantly in the neutral wire has been enrolled. Unbalanced loads also results in further declination of the Supply quality [1]. Various harmonic mitigation techniques have been proposed to reduce the effect of harmonics. These techniques include phase multiplication, passive filters, active power filters (APFs), and harmonic injection. One of the most popular APFs is the shunt active power filter. It is mainly a current source, Connected in parallel with the non-linear loads. Conventionally, a shunt APF is controlled in such a way as to inject harmonic and reactive compensation currents

based on calculated reference currents. The injected currents are meant to cancel the harmonic and reactive currents drawn by the nonlinear loads [2]. Recently, fuzzy logic controller has generated a great deal of Interest in various applications and has been introduced in the power electronics field [3]-[4].

The advantages of fuzzy logic controllers over the conventional PI controller are that they do not need an accurate mathematical model; they can work with imprecise inputs, can handle nonlinearity, and may be more robust than the conventional PI controller. Use of fuzzy logic for minimization of harmonics and improvement of power quality is not a new issue rather various authors have introduced some innovative methodologies using these tools[5]. The most important observation from the work reported by various researchers for power quality improvement is the Design of active power filter under ‘fixed load’ conditions or for loads with slow and small variation [6]. As loads in practical life are mostly variable, there is the need to design an active power filter, which is capable of maintaining the THD well within the IEEE norms [7], under variable load conditions. This paper, therefore, presents an auto tuned active power filter using Mamdani fuzzy-controller to control the harmonics under variable load conditions apart from balanced and unbalanced load conditions.

II. SHUNT ACTIVE POWER FILTER

In a modern electrical distribution system, there has been a sudden increase of nonlinear loads, such as power supplies, rectifier equipment, domestic appliances, and adjustable speed drives (ASD), etc. As the number of these loads increased, harmonics currents generated by these loads may become very significant. These harmonics can lead to a variety of different power system problems including the distorted voltage waveforms, equipment overheating, malfunction in system protection, excessive

neutral currents, light flicker, inaccurate power flow metering, etc. They also reduce efficiency by drawing reactive current component from the distribution network [8].

A. Basic compensation principal

In order to overcome these problems, active power filters (APFs) have been developed. The voltage-source-inverter (VSI)-based shunt active power filter has been used in recent years and recognized as a viable solution the control scheme, in which the required compensating currents are determined by sensing line currents only, which is simple and easy to implement. The scheme uses a conventional proportional plus integral (PI) controller for the generation of a reference current

APF. A current controlled voltage source inverter with necessary passive components is used as an APF as shown in fig 1. It is controlled to draw/supply a compensated current from/to the utility, such that it eliminates reactive and harmonic currents of the non-linear load. Thus, the resulting total current drawn from the ac mains is sinusoidal. Ideally, the APF needs to generate just enough reactive and harmonic current to compensate the non-linear loads in the line.

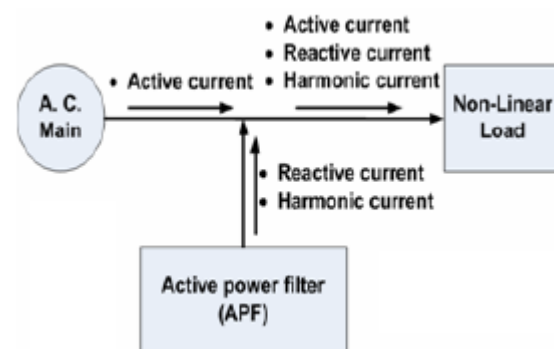

Fig. 1 Connection of shunt active filter with non-linear load

III. REFERENCE COMPENSATION CURRENT CALCULATION

The following equations describe the procedure used for reference compensation current calculations

$$\dot{i}_{load} = \dot{i}_{loadfund} + \dot{i}_{harmonics} \rightarrow (1)$$

$$\dot{i}_{loadfund} = |\dot{i}_{loadfund}| \sin \omega t \rightarrow (2)$$

The load current is a periodic function and according to Fourier series

$$\dot{i}_{load} = \frac{a_0}{2} + \sum_{n=1}^{\infty} [a_n \cos(n\omega t) + b_n \sin(n\omega t)]$$

Where

$$a_0 = \frac{1}{\pi} \int_{-\pi}^{\pi} \dot{i}_{load}(t) dt$$

$$a_n = \frac{1}{\pi} \int_{-\pi}^{\pi} \dot{i}_{load}(t) \cos(nt) dt$$

$$b_n = \frac{1}{\pi} \int_{-\pi}^{\pi} \dot{i}_{load}(t) \sin(nt) dt$$

$$|\dot{i}_{loadfund}| = \sqrt{(a_n^2 + b_n^2)}$$

$$\dot{i}_s^* = \dot{i}_{loadfund} + \dot{i}_{dc} \rightarrow (3)$$

The reference compensating current is

$$\dot{i}_s^* = (\dot{i}_{loadfund} + \dot{i}_{dc}) \sin \omega t \rightarrow (4)$$

$$\dot{i}_f^* = \dot{i}_s^* - \dot{i}_{load} \rightarrow (5)$$

$$\dot{i}_f^* = (|\dot{i}_{loadfund}| + \dot{i}_{dc}) \sin \omega t - (\dot{i}_{loadfund} + \dot{i}_{harmonics})$$

$$\dot{i}_f^* = \dot{i}_{dc} \sin \omega t - \dot{i}_{harmonics} \rightarrow (6)$$

B. Fuzzy Logic Current Controller

The desired switching signals for the filter inverter circuit are determined according to the error in the filter current using Fuzzy logic controller [8]-[9]. The parameters for the fuzzy logic current controller used in this paper are as follows. The design uses centrifugal defuzzification method. There are two inputs; error and its derivative and one output, which is the command signal to the PWM of the filter inverter. The two input uses Gaussian membership functions while the output use triangle membership function. The Fig.2, Fig.3 and Fig.4 represent the test system

simulation with balanced, unbalanced and variable loads

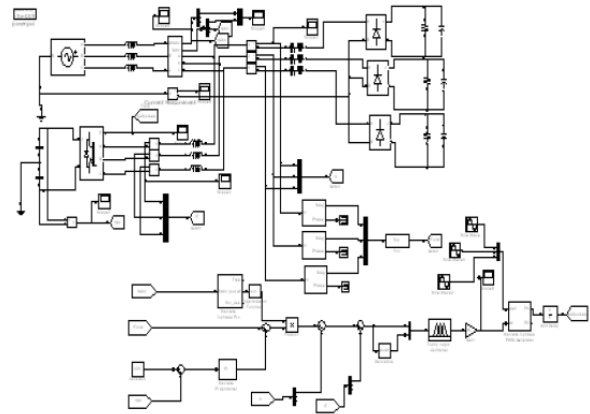

Fig. 2 The test system simulation with balanced nonlinear load

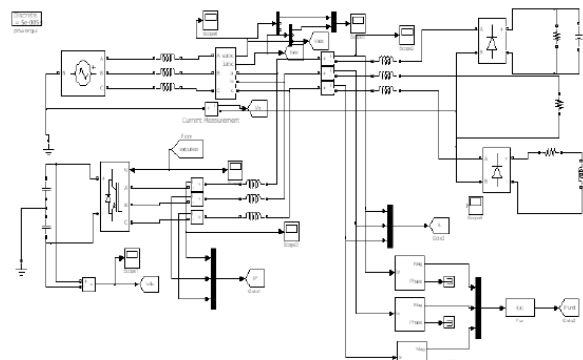

Fig. 3 The test system simulation with unbalanced nonlinear load

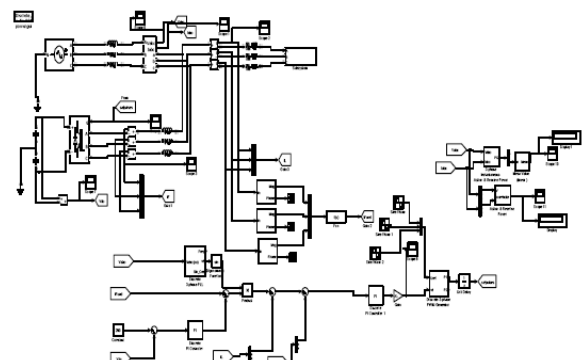

Fig. 4 The test system simulation with Variable nonlinear load

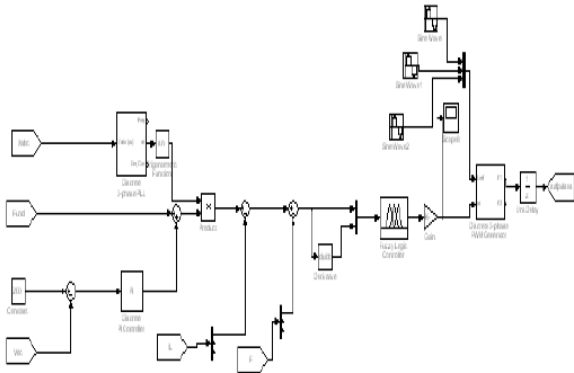

Fig. 5 Control strategy for shunt APF with Fuzzy.

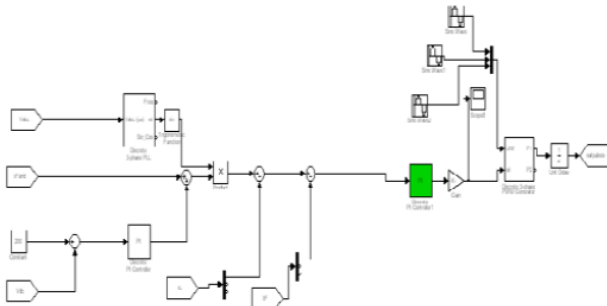

Fig. 6 Control strategy for shunt APF with PI-Controller

C. Proposed PI control scheme

The active power filter compensation system and the schematic diagram of the PI control scheme, respectively [8]-[9]. In order to implement the control algorithm of a shunt active power filter, the DC capacitor voltage (V_{dc}) is sensed and compared with the reference value (V_{dcref}). The Input of PI controller is the value of Error, $e = V_{dcref} - V_{dc}$, and its output, after a limit, is considered as the magnitude of peak reference current $max I$. The switching signal for the PWM converter are obtained from comparing the actual source currents (i_{sa}, i_{sb}, i_{sc}) with the reference current templates ($I_{sa}^*, I_{sb}^*, I_{sc}^*$) in a hysteresis current controller. The output pulses are applied to the switching devices of the PWM converter [14]. Since coefficients of PI controller, K_p and K_i , are fixed in this model, the performance of active power filter under random load variation conditions is not as well as ‘fixed load’ condition. To overcome this problem and make a robust controller, a fuzzy logic controller (FLC) is designed to tune K_p and K_i on the base of load current value.

The following Fig.7 fig. 8 shows FIS editor and FIS file viewer Fuzzy degree of membership for the error and its derivative and the command signal respectively.

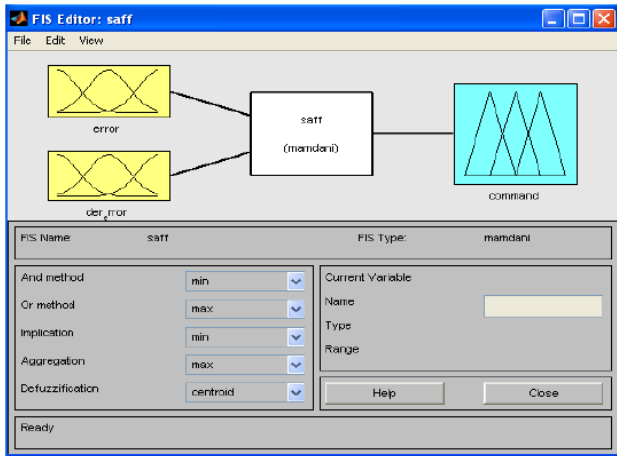

Fig. 7 FIS EDITOR

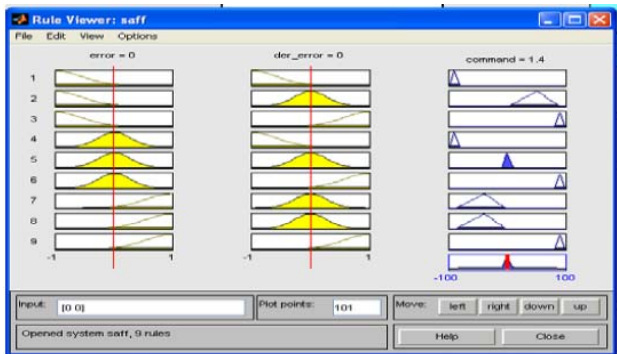

Fig. 8 FIS File Viewer

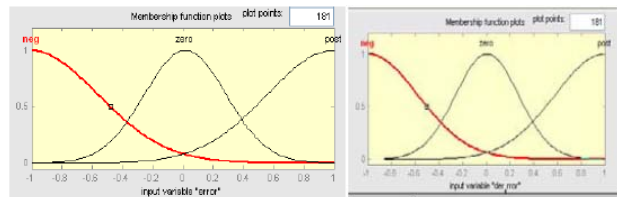

Fig. 8(a)

Fig. 8(b)

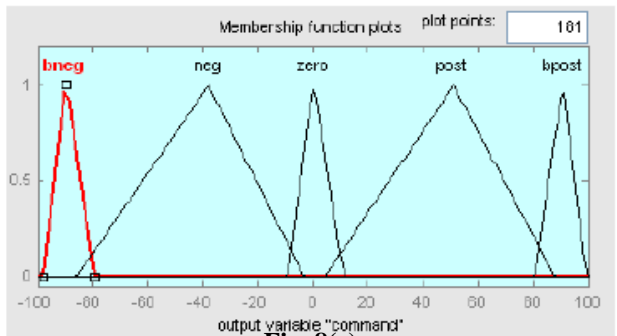

Fig. 8(c)

Fig. 8 The degree of membership for (a) the error, (b) Derivative, and (c) the command signal

Fig. 9 Simulation Results:

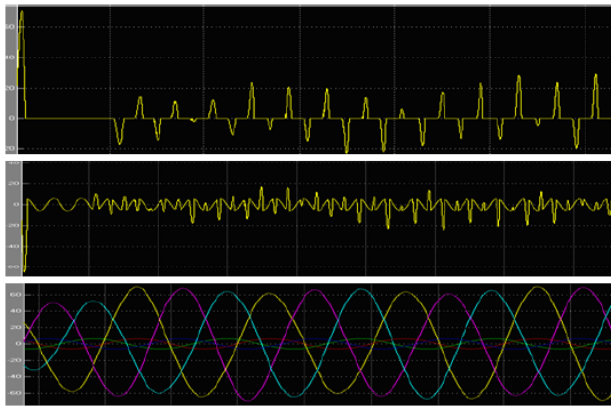

Fig. 9(a) Wave forms of load current, filter current, supply current and supply voltage of balanced non linear load Using PI control with respect to time

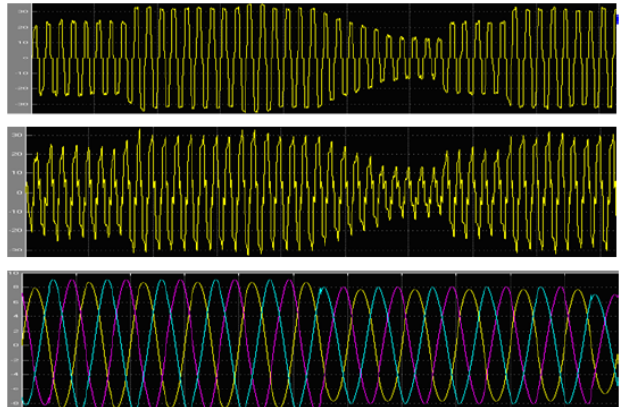

Fig. 9(d) Wave forms of load current, filter current, supply Current and supply voltage of unbalanced non linear load Using PI control with respect to time

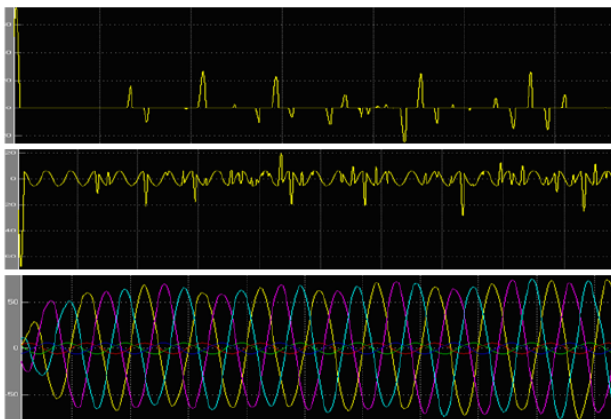

Fig. 9(b) Wave forms of load current, filter current, supply current and supply voltage of Unbalanced non linear load Using PI control with respect to time

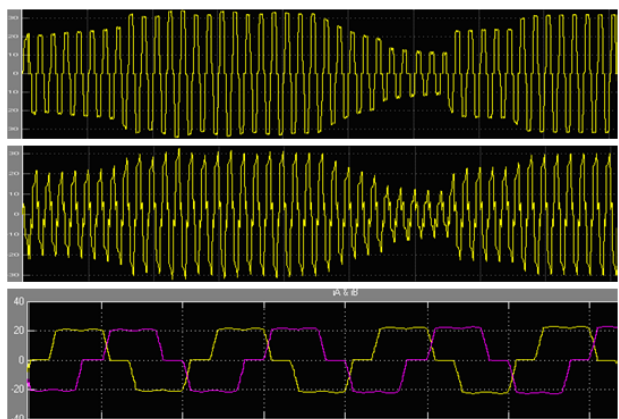

Fig. 9(e) Wave forms of load current, filter current, supply Current and supply voltage of Variable non linear load Using PI control with respect to time

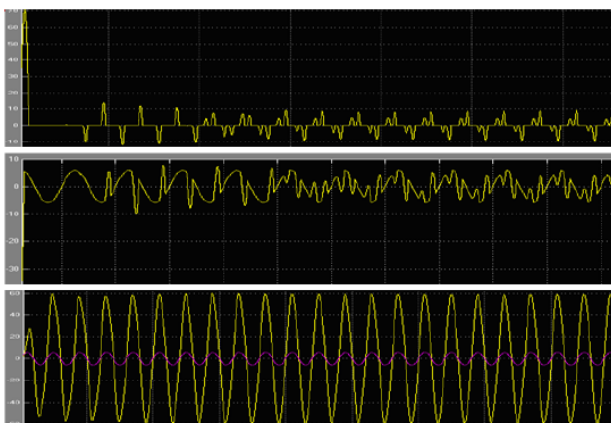

Fig. 9(c) Wave forms of load current, filter current, supply current and supply voltage of balanced non linear load Using Fuzzy control with respect to time



Fig. 9(f) Wave forms of load current, filter current, supply Current and supply voltage of Variable non linear load Using Fuzzy control with respect to time

IV. COMPARISON OF % THD, POWER FACTOR AND REACTIVE POWER COMPENSATION TABLE USING PI AND FUZZY CONTROL.

Control Scheme → Type Of loads ↓	PI				Fuzzy			
	THD (%)	POWER FACTOR	Reactive Power(Var)		THD	POWER FACTOR	Reactive Power(Var)	
			With Filter	With Out filter			With Filter	With Out filter
Balanced Load	4.9	0.8555	51.12	125.9	2.82	0.972	17.6	125
Unbalanced load	2.84	0.9996	19.38	31.67	2.82	0.9997	33	31.67
Variable load	2.82	0.9993	36.26	52.6	1.56	0.9999	38	51

V. CONCLUSION

The proposed Shunt Active Filter (SAF) can compensate for balanced, unbalanced and Variable nonlinear load currents. Proposed SAF adapt itself to compensate for variation in non linear currents. Simulation results shown that system limits THD percentage of source current under limits of IEEE-519 standard (5%), and also observed that Power factor and Reactive power compensation is improved.

REFERENCES

[1] A. Elmitwally, S. Abdelkader, M. Elkateb "Performance evaluation of fuzzy controlled three and four wireshunt active power conditioners" IEEE Power Engineering Society Winter Meeting, 2000. Volume 3, Issue, 23-27 Jan 2000 Page(s):1650 - 1655 vol.3.

[2] G. K. Singh, "Power system harmonics research: a survey" European Transactions on Electrical Power, 2009 Page(s):151 – 172.

[3] B. K. Bose, Expert Systems, Fuzzy Logic and Neural Network Application in Power Electronics and Motion Control. Piscataway, NJ: IEEE Press, 1999, ch. 11.

[4] Dell'Aquila, A. Lecci, and V. G. Monopoli, "Fuzzy controlled active filter driven by an innovative current reference for cost reduction," in proc. IEEE Int. symp. Ind. Electron., vol. 3, May 26-29, 2002, pp. 948-952.

[5] B.Singh, A. Chandra, and K. Al-Haddad, "Computer-aided modeling and simulation of active power filters," *Elect. Mach. Power Syst.*, vol. 27, pp. 1227-1241, 1999.

[6] G.K. Singh, A.K. Singh, R. Mitra., "a simple fuzzy logic based robust active power filter for harmonics minimization under random load variation" *Electr. Power Syst. Res.* (2006).

[7] Recommended Practices and Requirements for Harmonic Control in Electronic Power Systems, IEEE Standard 519-1992, New York, 1993

[8] S. S. Mortazavi, R. Kianinezhad, A. Ghasemi Auto Tuned Robust Active Power Filter for Power Quality Improvement under Fast Load Variation

[9] Ahmed A. Helal, Nahla E. Zakzouk, and Yasser G. Desouky "Fuzzy Logic Controlled Shunt Active Power Filter for Three-phase Four-wire Systems with Balanced and Unbalanced Loads"